

23. TRIGONOMETRY

SOLUTION OF RIGHT-ANGLED TRIANGLES

Trigonometry is the branch of mathematics that describes the relationship between the angles and lengths of triangles. It is used to calculate distances in the real world when it is difficult to measure these directly. It was first used in navigation and now it has gained widespread use in fields such as architecture, surveying, engineering, the manufacturing industry and many other fields.

Calculations of these distances depend on the geometric properties of triangles and so we need to be familiar with the notation for naming sides and angles of triangles.

The standard notation for a triangle

In the standard notation for a triangle, we usually name the sides that are opposite an angle, by the common letter that names the angle.

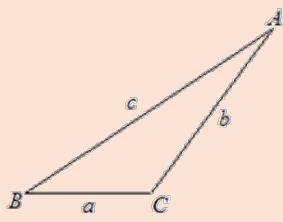
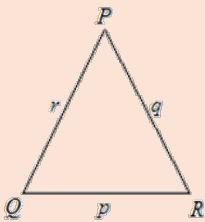
	
The sides opposite angle A is named, a . The side opposite angle B is named, b . The side opposite angle C is named c .	The side opposite angle P is named p . The side opposite angle Q is named q . The side opposite R is named r .

Right angled triangles

The sides of a right-angled triangle have special names. When naming the sides, it is quite convenient to firstly name the hypotenuse, since it is the only side that is fixed. The other two sides are named in relation to the acute angle being considered and these are named after the said angle is identified.

The diagram below illustrates this principle.

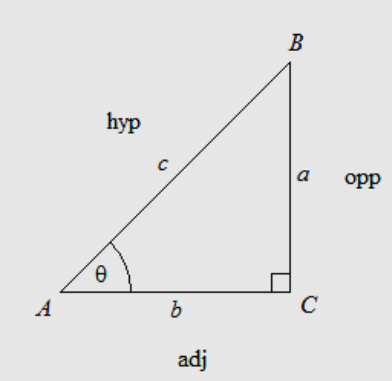

The side opposite the right angle is called the hypotenuse.

With reference to the acute, θ , at A , the side BC is opposite to the angle θ and called the opposite side.

The third side, AC is called the adjacent side since it is next to the angle θ .

Consider another right-angled triangle, PQR with an acute angle α , at Q . We use the same principle outlined above to identify and name each side.

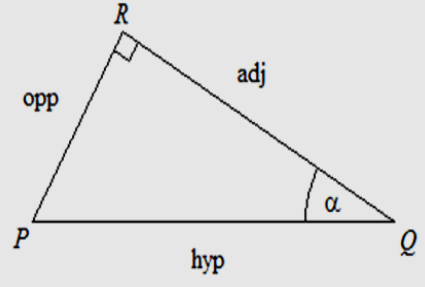

The hypotenuse is opposite to the right angle and in this case, it is PQ .

The side PR is the opposite side since it is opposite to the angle α .

The third side is QR which is called the adjacent side since it is next to the angle α .

Solving triangles

Solving a triangle means we must be able to determine the values of all its elements. Triangles have six elements- three sides and three angles. A triangle is specified by three elements and we need to be given to solve for the remaining elements a minimum of three elements to solve for the remaining ones. These three elements that specify a triangle can be any of the following combinations:

1. Two sides and the angle included by the sides
2. Two angles and their common arm.
3. Three sides
4. Right angle, hypotenuse and one side.

Pythagoras' Theorem

In our study of triangles earlier, we saw that we can use Pythagoras' Theorem to solve for an unknown side of a right-angled triangle if we know the lengths of the other two sides. In applying this theorem, the three elements to be considered are the right angle and any two sides. This theorem is stated below.

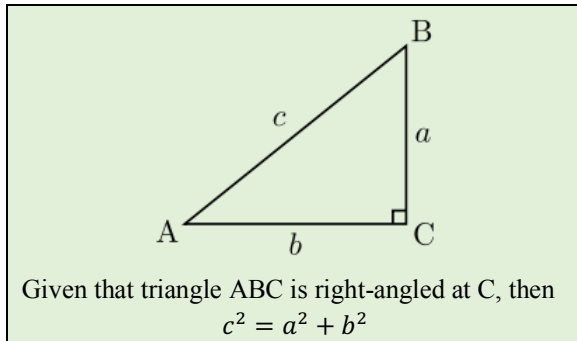

Trigonometry provides another option for solving triangles. We will now introduce the trigonometric ratios that are used to solve right-angled triangles.

Introducing trigonometric ratios

The trigonometric ratios are useful when finding the unknown side of a right-angled triangle. When we studied triangles, we learnt that two triangles are similar when all their corresponding angles are the same.

The three triangles below, have the same angles but they differ in size. These triangles are similar and from the property of similar triangles, we can also deduce that the ratio of their corresponding sides is the same.

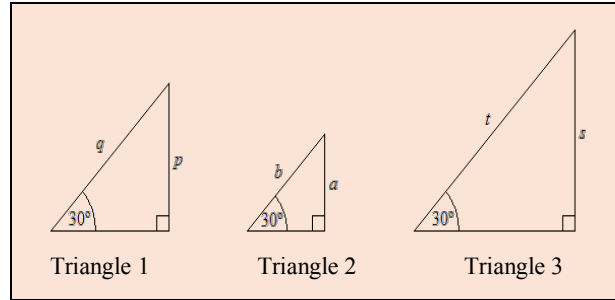

Using the property of similar triangles, in the triangles 1 and 2, we can write a pair of equivalent ratios as shown below:

$$\frac{p}{a} = \frac{q}{b}$$

Note these ratios are between triangles. However, the above ratios can be rearranged algebraically so that:

$$\frac{p}{q} = \frac{a}{b}$$

Note that these ratios are now within triangles.

Similarly, by comparing triangles 1 and 3, we can write

$$\frac{p}{s} = \frac{q}{t}$$

Arranging these ratios algebraically, we have:

$$\frac{p}{q} = \frac{s}{t}$$

Combining ratios, we can therefore state

$$\frac{p}{q} = \frac{a}{b} = \frac{s}{t} = k$$

This constant, k is a trigonometric ratio, defined as the sine ratio for the angle 30° . We can obtain its value from a calculator or book of trigonometrical tables. It has a value of 0.5 in this case.

If we were to draw an infinite number of triangles equiangular to Triangle 1, then the following ratio will hold:

$$\frac{\text{Length of the side opposite to } 30^\circ}{\text{Hypotenuse}} = 0.5$$

The ratio is different for different angles, yet constant for that particular angle. By comparing other pairs of sides within a triangle, we can define other ratios.

Trigonometric ratios

For any given right-angled triangle, the ratio of pairs of the sides is constant. There are really six possible pairs but three of these are the inverse of the other pairs. For example, we can pair side a with side c in two ways:

$$\frac{a}{c} \text{ or } \frac{c}{a}$$

The ratio $\frac{c}{a}$ is the inverse of the ratio $\frac{a}{c}$ or vice versa. In the right-angled triangle, ABC , shown below we will only be concerned with the names of the three ratios:

$$\frac{a}{c} \text{ and } \frac{b}{c} \text{ and } \frac{a}{b}$$

These ratios are called trigonometric ratios and will be defined with reference to the acute angle, $A = \theta^\circ$.

The side opposite the right angle, AB is the hypotenuse whose length is c .

The side opposite the angle θ , BC is the opposite side whose length is a .

The remaining side, AC is the adjacent side whose length is b .

We now define the three commonly used trigonometric ratios.

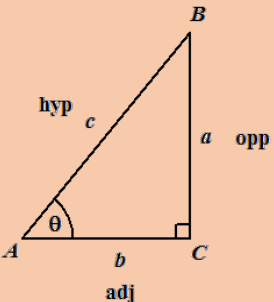

The sine ratio (abbreviated sin)

$$\sin \theta = \frac{\text{opp}}{\text{hyp}} = \frac{a}{c}$$

The cosine ratio (abbreviated cos)

$$\cos \theta = \frac{\text{adj}}{\text{hyp}} = \frac{b}{c}$$

The tangent ratio (abbreviated tan)

$$\tan \theta = \frac{\text{opp}}{\text{adj}} = \frac{a}{b}$$

We will now demonstrate the use of these ratios in solving for unknown elements in triangles.

Example 1

Calculate the value of y , in the triangle shown.

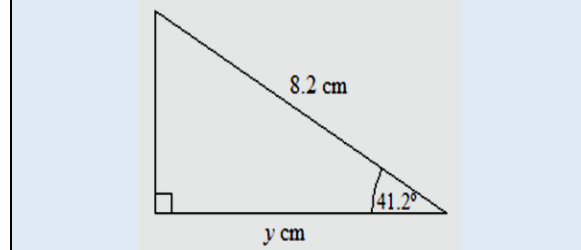

Solution

The given side is the **hypotenuse** and the unknown side is **adjacent** to 41.2° . The cosine ratio connects these two sides.

$$\begin{aligned} \cos 41.2^\circ &= \frac{y}{8.2} \\ \therefore y &= 8.2 \times \cos 41.2^\circ \\ &= 6.169 \\ &= 6.17 \text{ to 2 decimal places} \end{aligned}$$

Example 2

In the figure shown, calculate the value of x .

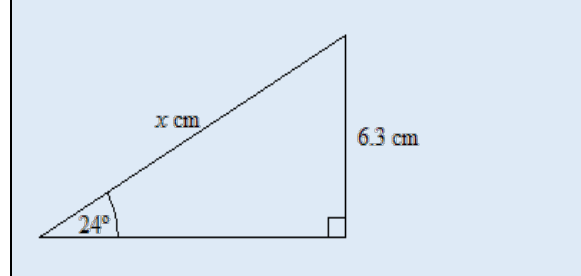

Solution

The given side is **opposite** 24° and the unknown side is the **hypotenuse**. The sine ratio connects these two sides.

$$\begin{aligned} \sin 24^\circ &= \frac{6.3}{x} \\ \therefore x &= \frac{6.3}{\sin 24^\circ} \\ &= 15.489 \\ &= 15.49 \text{ to 2 decimal places} \end{aligned}$$

Example 3

Calculate the size of the angle, α to the nearest 0.1° .

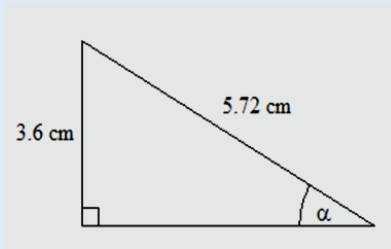

Solution

We are given the **hypotenuse** and the side **opposite** to α . The sine ratio connects these two sides.

$$\sin \alpha = \frac{3.6}{5.72}$$

$\therefore \alpha$ is the angle whose sine is $\frac{3.6}{5.72}$.

$$\begin{aligned} \text{This is written as } \alpha &= \sin^{-1}\left(\frac{3.6}{5.72}\right) \\ &= 39.00^\circ \\ &= 39.0^\circ \text{ to the nearest } 0.1^\circ \end{aligned}$$

Example 4

Calculate the size of the angle, α to the nearest 0.1° .

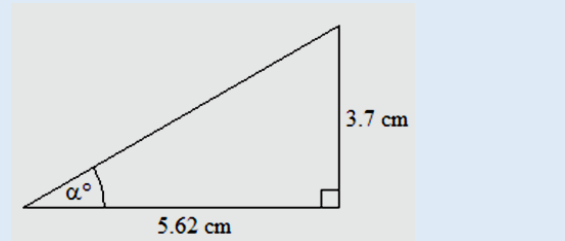

Solution

We are given the side **adjacent** to α and the side **opposite** to α . The tangent ratio connects these two sides.

$$\tan \alpha = \frac{3.7}{5.62}$$

$$\therefore \alpha = \tan^{-1}\left(\frac{3.7}{5.62}\right)$$

$$= 33.35^\circ$$

$$= 33.4^\circ \text{ to the nearest } 0.1^\circ$$

Example 5

In the triangle below, calculate the length of the hypotenuse.

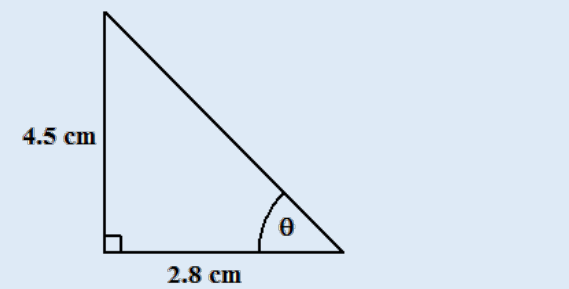

Solution

We can choose to use Pythagoras' theorem. Letting h represent the hypotenuse.

$$h^2 = 4.5^2 + 2.8^2$$

$$h^2 = 20.25 + 7.84 = 28.09$$

$$h = \sqrt{28.09}$$

$$h = 5.3$$

Alternatively, we could have used trigonometry, as shown below.

$$\tan \theta = \frac{4.5}{2.8}$$

$$\theta = \tan^{-1}\left(\frac{4.5}{2.8}\right)$$

$$\theta = 58.1^\circ$$

$$\sin 58.1 = \frac{4.5}{h}$$

$$h = \frac{4.5}{\sin 58.1} = \frac{4.5}{0.85}$$

$$h = 5.3$$

SOLUTION OF NON-RIGHT-ANGLED TRIANGLES

The above section dealt with the solution of only right-angled triangles. But these ratios cannot be applied to non-right angled triangles. We will now explore two rules that will be used for other triangles. The choice between the two depends on what combination of three elements is given.

Sine rule

Consider any triangle ABC .

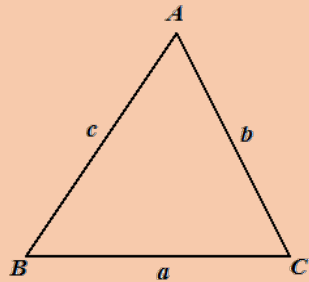

The Sine Rule states that

$$\frac{a}{\sin \hat{A}} = \frac{b}{\sin \hat{B}} = \frac{c}{\sin \hat{C}}$$

In using the rule to find an unknown side, we must be given any three parts of the ratio:

$$\frac{a}{\sin \hat{A}} = \frac{b}{\sin \hat{B}}$$

or
$$\frac{a}{\sin \hat{A}} = \frac{c}{\sin \hat{C}}$$

or
$$\frac{b}{\sin \hat{B}} = \frac{c}{\sin \hat{C}}$$

The Cosine Rule

In some instances, we are given three elements but they do not allow the setting up of the sine rule. For example, if we need to solve the following triangle, there are no matching pairs of sides to angles given.

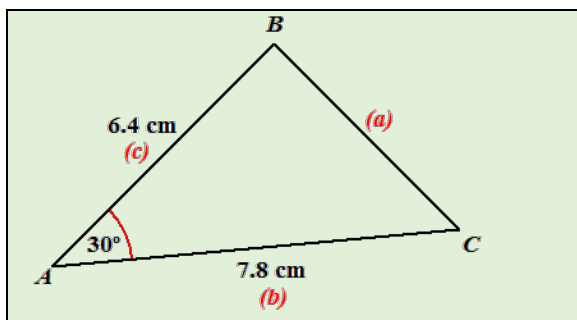

In such a case, we cannot apply the sine rule. Hence, we might be able to use another rule called the cosine rule.

The Cosine Rule

Consider any triangle ABC .

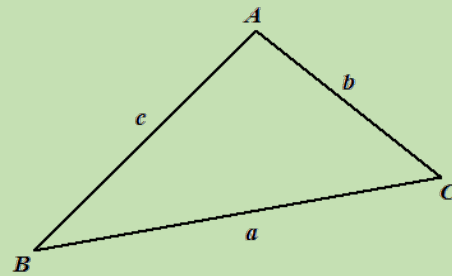

$$a^2 = b^2 + c^2 - 2bc \cos \hat{A}$$

OR
$$b^2 = a^2 + c^2 - 2ac \cos \hat{B}$$

OR
$$c^2 = a^2 + b^2 - 2ab \cos \hat{C}$$

Note that each form has four quantities. If we know any three, the fourth can be found.

By observing the pattern in each of the above forms of the cosine rule, we must note that to solve for an unknown side, the other two sides must be given as well as the angle opposite the unknown side.

We may also use the cosine rule to find an unknown angle, but in such a case, all three sides of the triangle must be given.

It should also be noted that the sine and cosine rules hold for any triangle, even right-angled triangles but it is much easier to use the trigonometric ratios when solving right-angled triangles. In solving non-right-angled triangles, we select either the sine or cosine rule depending on the given information.

Example 6

Calculate the size of $\angle ACB$.

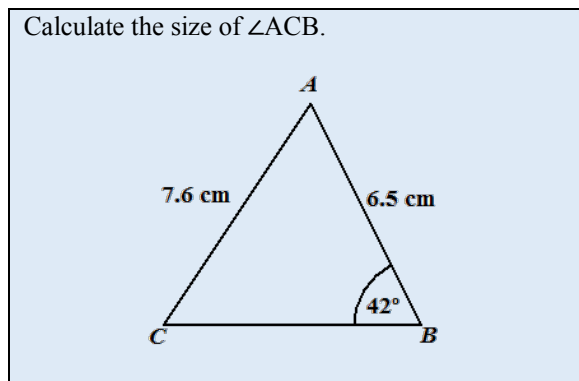

Solution

In setting up ratios using the sine rule we match a side to the angle opposite it as shown.

So, 7.6 will be matched with 42° , and 6.5 will be matched with $\angle C$.

$$\begin{aligned}\frac{7.6}{\sin 42^\circ} &= \frac{6.5}{\sin \hat{C}} \\ 7.6 \times \sin \hat{C} &= 6.5 \times \sin 42^\circ \\ \sin \hat{C} &= \frac{6.5 \times \sin 42^\circ}{7.6} \\ &= 0.5722 \\ C &= \sin^{-1}(0.5722) \\ &= 34.9^\circ\end{aligned}$$

Example 7

Calculate the length of AB correct to 2 decimal places.

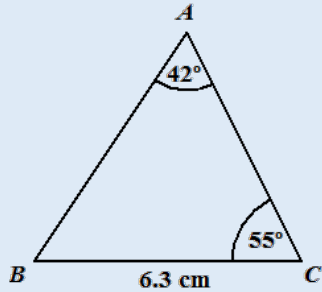

Solution

Matching sides with their opposite angles, we have

6.3 will be matched with 42° , and AB will be matched with $\angle C$.

$$\begin{aligned}\frac{6.3}{\sin 42^\circ} &= \frac{AB}{\sin 55^\circ} \\ AB \times \sin 42^\circ &= 6.3 \times \sin 55^\circ \\ AB &= \frac{6.3 \times \sin 55^\circ}{\sin 42^\circ} \\ AB &= 7.71 \text{ cm}\end{aligned}$$

Example 8

Calculate AB

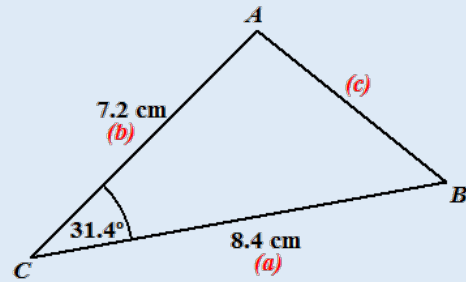

Solution

By the cosine rule

$$\begin{aligned}c^2 &= a^2 + b^2 - 2ab \cos \hat{C} \\ c^2 &= (8.4)^2 + (7.2)^2 - 2(8.4)(7.2) \cos 31.4^\circ \\ c^2 &= 70.56 + 51.84 - 103.245 \\ c^2 &= 19.155 \\ c &= 4.377\end{aligned}$$

Example 9

Calculate the size of angle BAC, given $AC = 8.2$ m, $AB = 5.7$ m and $BC = 4.9$ m

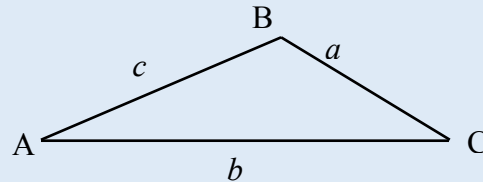

Solution

$$\begin{aligned}a^2 &= b^2 + c^2 - 2bc \cos A \\ 4.9^2 &= 8.2^2 + 5.7^2 - 2(8.2)(5.7) \cos(\theta) \\ 24.01 &= 99.73 - 93.48 \cos(\theta) \\ \cos(\theta) &= \frac{99.73 - 24.01}{93.48} \\ \cos(\theta) &= 0.8100 \\ \theta &= 35.9^\circ\end{aligned}$$

APPLICATION OF TRIGONOMETRY

We will now examine how we can use trigonometry to solve problems in the real world. We will relate objects in the physical world to positions in three-dimensional space and use trigonometry to calculate unknown distances between two points in a plane or two points in space. In the following section, we will use triangles and laws of trigonometry to calculate unknown distances such as the height of a cliff and the depth or breadth of an ocean.

Angles of Elevation and Depression

These angles are defined in relation to an observer who may be looking up or looking down at an object.

Angle of Elevation

When an object is above the level of an observer, we have an angle of elevation.

The angle of elevation, as seen by an observer, is the angle between the horizontal (drawn in line with the observer's eye) and the line drawn from the observer to the object (line of vision or sight).

The angle of elevation, denoted by α° is shown in the diagram below.

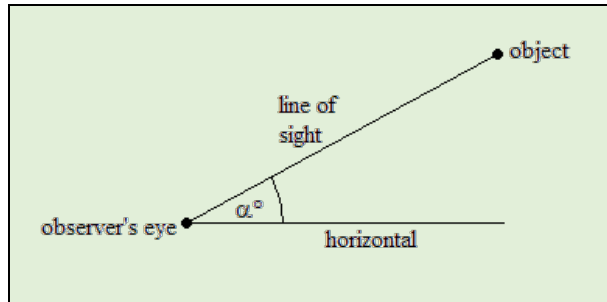

Angle of Depression

When an object is below the level of an observer, we have an angle of depression.

The angle of depression, as seen by an observer, is the angle between the horizontal (drawn in line with the observer's eye) and the line drawn from the observer to the object (line of vision or sight).

The angle of depression, denoted by θ° is shown in the diagram below.

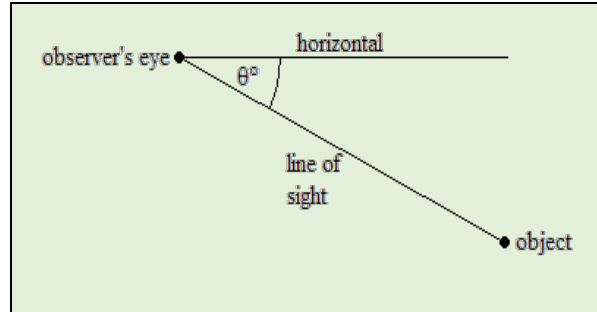

Relationship between the angle of elevation and the angle of depression

Both the angle of elevation and the angle of depression are measured from the **horizontal** drawn from the observer. If the observer is at A looking up at the object at B then there is an angle of elevation at A . If the observer is at B looking down at an object at A , then there is an angle of depression at B .

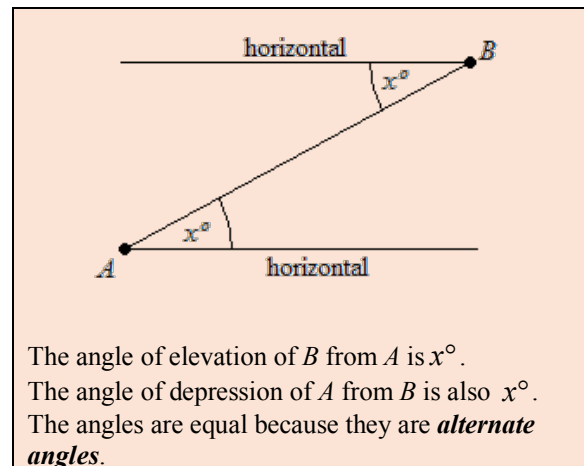

The angle of elevation of B from A is x° .
The angle of depression of A from B is also x° .
The angles are equal because they are **alternate angles**.

A typical problem on angles of elevation and depression involves calculating distances and angles within a right-angled triangle.

Example 1

An observer situated at a point A , on the top of a vertical cliff of height 50 m, looks down at a steamer located at point B , an unknown distance away from the base of the cliff. If the angle of depression of B from A is 24° .

Calculate the horizontal distance between the object and the base of the cliff.

Solution

We draw a diagram to show the angle of depression and the rest of the given data.

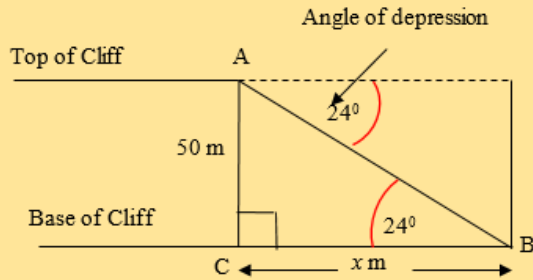

Since the cliff is vertical, angle $ACB = 90^\circ$.
The angle of depression, 24° , is shown at the top of the cliff.

Consider the triangle ABC
 $ABC = 24^\circ$ (alternate angles).

Let the distance between the object, B and the base of the cliff be x .

We are given the height of the cliff, $AC = 50$ m and we wish to find x . With reference to angle ABC, the side AC is opposite and the side BC is adjacent.

Hence, we use the tangent ratio.

$$\tan 24^\circ = \frac{50}{x}$$

$$x = \frac{50}{\tan 24^\circ}$$

$$x = 112.3 \text{ m}$$

The distance between the object and the base of the cliff is 112.3 m

Example 2

An observer, at A, on horizontal ground, observes the top of a building at an angle of elevation of 27° . Another observer at B, 10 m away from A and on the same horizontal plane, observes the angle of elevation of the top of the building is 38° .

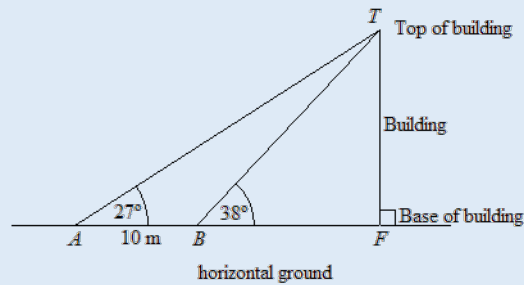

Calculate the height of the building.

Solution

Let F be the base of the building and T be the top of the building. The information is shown in the diagram below.

We need to find TF but we do not have the lengths of any side in triangle TBF. However, in triangle TAB we know AB and the angle at A. We can find the remaining angles in the triangle as shown.

$$\begin{aligned} \hat{TBA} &= 180^\circ - 38^\circ & \hat{ATB} &= 180^\circ - (27^\circ + 142^\circ) \\ &= 142^\circ & &= 11^\circ \end{aligned}$$

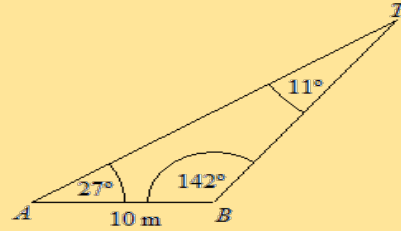

We can now find the length of TB by using the sine rule in $\triangle TAB$.

$$\frac{TB}{\sin 27^\circ} = \frac{10}{\sin 11^\circ}$$

$$\therefore TB = \frac{10 \times \sin 27^\circ}{\sin 11^\circ}$$

$$= 23.793 \text{ m}$$

We can now solve for the height of the building using triangle TBF.

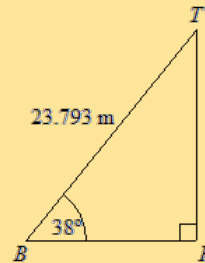

$$\sin 38^\circ = \frac{TF}{23.793}$$

$$\therefore TF = 23.793 \sin 38^\circ$$

$$= 14.648$$

$$= 14.65 \text{ m to 2 decimal places}$$

Therefore, the height of the building is 14.65 m

Angle of Elevation of the sun

The angle of elevation of the sun is the angle between the horizontal and the line of vision if one is able to look up at the sun. We usually measure this by erecting a vertical pole and measuring the length of the shadow, as shown in the diagram below.

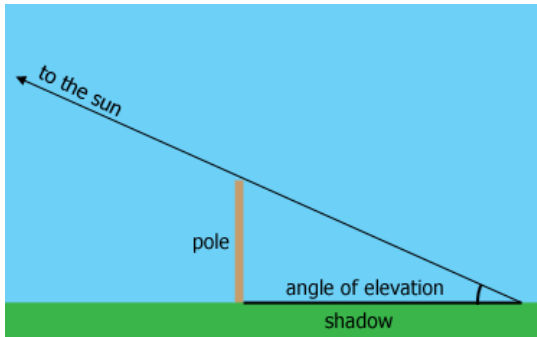

Example 3

A tree, 50 m tall and standing at a right angle to the ground, casts a shadow of 60 m. Calculate the angle of elevation of the top of the tree from the furthest edge of the shadow.

Solution

Solution Let α° be the angle of elevation of the sun. The diagram shows the height of the tree and the length of its shadow.

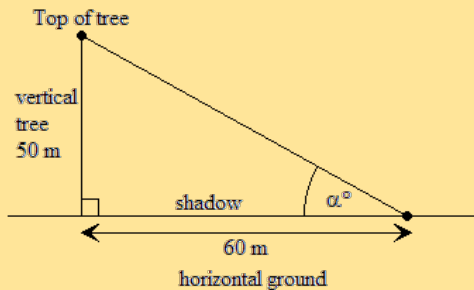

With reference to α , the opposite and adjacent sides of the triangle are 50 m and 60 m respectively. Hence, we may use the tangent ratio,

$$\begin{aligned}\tan \alpha^\circ &= \frac{50}{60} \\ \therefore \alpha^\circ &= \tan^{-1}\left(\frac{50}{60}\right) \\ &= 39.80 \\ &= 39.8^\circ \text{ to the nearest } 0.1^\circ\end{aligned}$$

Example 4

The diagram, not drawn to scale, shows a vertical tower FT of height 25 m. Three points, R , F and T are on horizontal ground such that R is due East of F and the angle of elevation of T from R is 27° . S is due South of F and $SF = 43.3$ m.

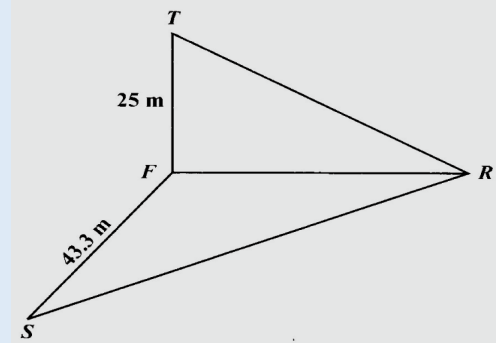

- (a) Calculate the length of (i) RF and (ii) SR , correct to one decimal place.
(b) Calculate, to 1 decimal place, the angle of elevation of the top of the tower, from S .

Solution- Part (a)

(a) (i) RTF is a right-angled triangle because FT is a vertical tower. Angle TRF is 27° since it is the angle of elevation of T from R .

$$\begin{aligned}\tan 27^\circ &= \frac{25}{RF} \\ \therefore RF &= \frac{25}{\tan 27^\circ} \\ &= 49.06 \text{ m} \\ &= 49.1 \text{ m}\end{aligned}$$

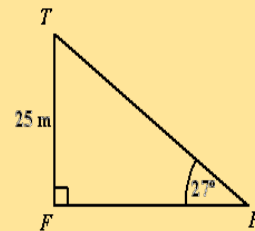

(a) (ii) In triangle SRF , R is east of F and S is south of F , angle SFR is a right angle. We are given SF and we calculated RF above.

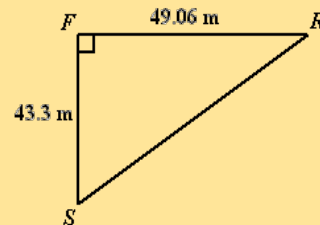

$$\begin{aligned}SR^2 &= (49.06)^2 + (43.3)^2 \quad (\text{Pythagoras' Theorem}) \\ &= 2406.88 + 1874.89 \\ &= 4281.77 \\ SR &= \sqrt{4281.77} \\ &= 65.43 \text{ m} \\ &= 65.4 \text{ m correct to 1 decimal place}\end{aligned}$$

Solution Part (b)

To calculate the angle of elevation of the top of the tower, T , from S , we need to draw the triangle TFS and insert the angle of elevation. We know that this triangle is right-angled as T is a vertical tower and we know the length of the sides FT and SF .

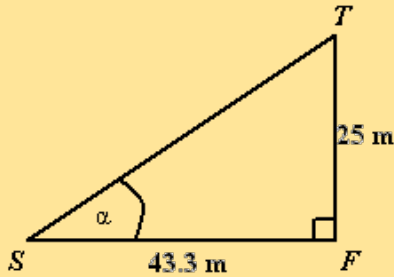

Let the angle of elevation, TFS , be α .

$$\tan \alpha^\circ = \frac{25}{43.3}$$

$$\alpha^\circ = \tan^{-1}\left(\frac{25}{43.3}\right)$$

$$\alpha = 30.00$$

$$= 30.0 \text{ to 1 decimal place}$$

Bearings

In our study of trigonometry so far, we have been calculating unknown distances in triangles. We were given certain elements of a triangle and used either the trigonometric ratios or the sine and cosine rule to solve for any of the elements of the triangles.

In the application of trigonometry to real-world problems, we will now learn to use angles to describe the position of one point with reference to another. Often in navigation, it is necessary to determine the relative position of objects and to calculate the distance of journeys. The rules we learned in trigonometry can be applied to solve problems involving both directions and distances.

We use bearings to tell the direction of one point from another. We will now compare how bearings relate to the four cardinal points.

Bearings and the Cardinal Points

The four cardinal points are East, West, North and South. We often use it to describe the position of one place on a map in relation to another place. For positions that fall exactly between any two cardinal

points, say between North and East, we use NE, and between South and East, we use SE, between South and West we use SW and between West and North we use NW. The diagram below shows these directions.

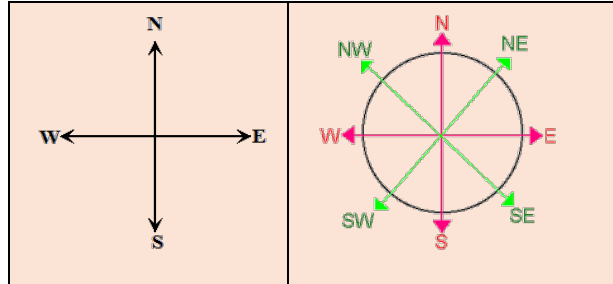

Using the cardinal points, we can also describe the position of points that do not fall on exactly on any of these eight positions. To describe the position of the points P and R from the origin, we follow the conventions shown below.

	<p>Since P lies closer to North (N) than East (E). The angle measured from the north is 20°. Therefore, the direction of P is N, 20° E.</p>
	<p>The point R is closer to East (E) than north (N). The angle, measured from north is 20°. Therefore, the direction of R is E, 20° N.</p>

Although the cardinal points are widely used, there is a measure of direction which does not refer to any cardinal point, only an angle. This measure is referred to as bearings. If we were to describe the four cardinal points using bearings, then the directions would be read as shown below.

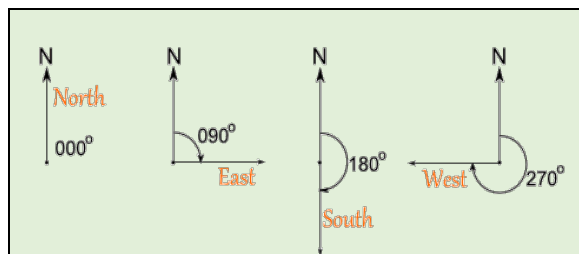

The NE, NW, SW and SE directions, these would be described using bearings as follows.

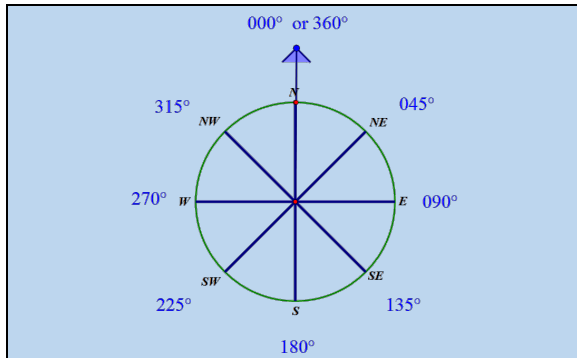

Assuming that a compass needle is pointing exactly north, when it makes a clockwise turn of 45° , it will be pointing NE.
 After a clockwise turn of 135° , the needle will point to SE.
 After a clockwise turn of 225° , the needle will point to SW.
 After a clockwise turn of 315° , the needle will point to NW.

We can now define a bearing.

Bearing

A bearing is a direction measured from North in a clockwise direction and is given only by an angle. Bearings must always be written using three digits. For angles less than 100° , we place a zero or zeros in front of the number so as to ensure there are three digits. For example,
 North is on a bearing of 000° .
 North East is on a bearing of 045° .

Measuring bearings

How do we measure the bearing of one point from another? Consider two points A and B . We are interested in finding the bearing of A from B . This means if a person is at B , he wants to know what is A 's bearing is from him. We can also say what is A 's direction from B ?

In solving problems on bearings, it is recommended that we set up a compass at each of the two points we are interested. In this case, at A and B . Next, we join the points A and B . We now measure direction from B by identifying the angle between the North line and the line segment measured in a clockwise direction.

We are given the points A and B as shown

A .

B .

First set up a compass at A and at B , then join AB .

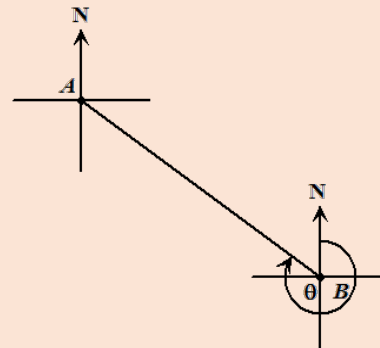

The angle that the line AB makes with the North line at B is the bearing of A from B . This is shown by θ° in the diagram.

If however, we were interested in the bearing of B from A , then we follow the same steps as above but the angle is measured at the point A instead of B .

A .

B .

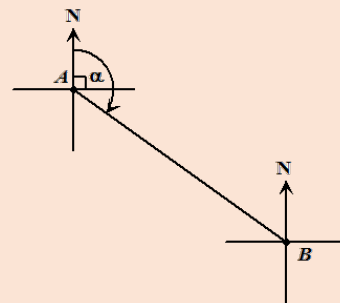

The angle that the line AB makes with the North line at A is the bearing of B from A . This is shown by α in the diagram.

Example 7

The bearing of P from Q is 120° . Find the bearing of Q from P .

Solution

The bearing of P from Q is 120° . Note the bearing is measured at Q .

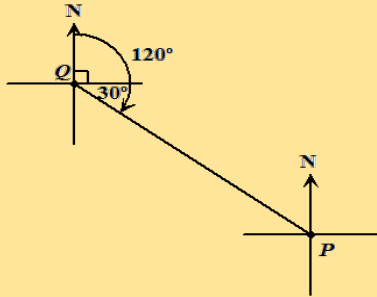

The bearing of Q from P is 300° . Note the bearing is measured at P .

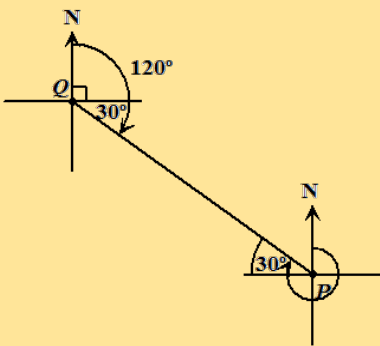

Example 8

The diagram shows the route of an aeroplane flying from point P to Q and then to R . The bearing of Q from P is 132° and the angle PQR is 56° . The distance from P to Q is 220 km and the distance from Q to R is 360 km. Calculate

- the value of x
- the distance RP
- the bearing of R from P .

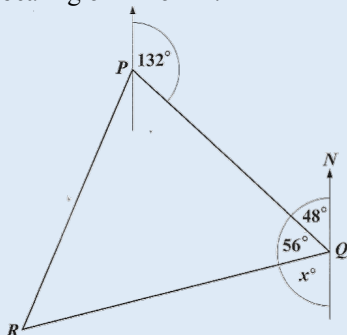

Solution

(i)

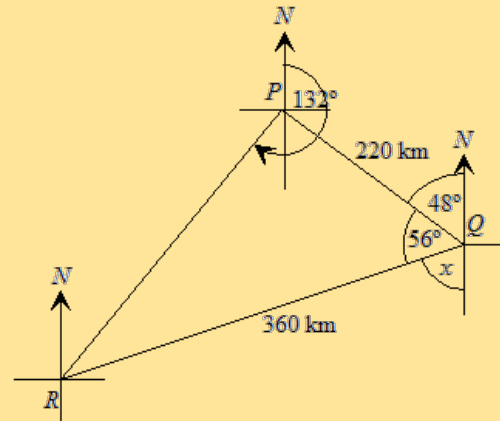

$$x^\circ = 180^\circ - (48^\circ + 56^\circ) = 76^\circ$$

(Angles in a straight line = 180°)

(ii) Applying the cosine rule to triangle PQR

$$RP^2 = 220^2 + 360^2 - 2(220)(360) \cos 56^\circ$$

$$RP^2 = 48400 + 129600 - (158400) \cos 56^\circ$$

$$RP = \sqrt{178000 - (158400) \cos 56^\circ}$$

$$RP = \sqrt{89423.84}$$

$$RP = 299.0 \text{ km}$$

(iii)

$$\frac{RQ}{\sin RPQ} = \frac{RP}{\sin 56^\circ}$$

$$\frac{360}{\sin RPQ} = \frac{299}{\sin 56^\circ}$$

$$\sin RPQ = \frac{360 \times \sin 56^\circ}{299}$$

$$RPQ = \sin^{-1} \left(\frac{360 \times \sin 56^\circ}{299} \right)$$

$$= 86.5^\circ$$

Bearing is the direction measured from north in a clockwise direction.

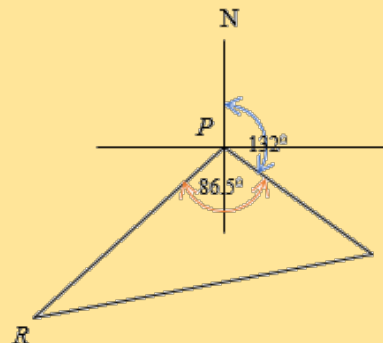

$$\therefore \text{Bearing of } R \text{ from } P = 132^\circ + 86.5^\circ = 218.5^\circ$$

SOLID TRIGONOMETRY

We can use trigonometry and Pythagoras' Theorem to calculate unknown lengths of sides and angles within solids.

Internal Diagonals

Let us examine a cuboid whose dimensions are given as shown. We wish to calculate the length of the internal diagonal labelled, d .

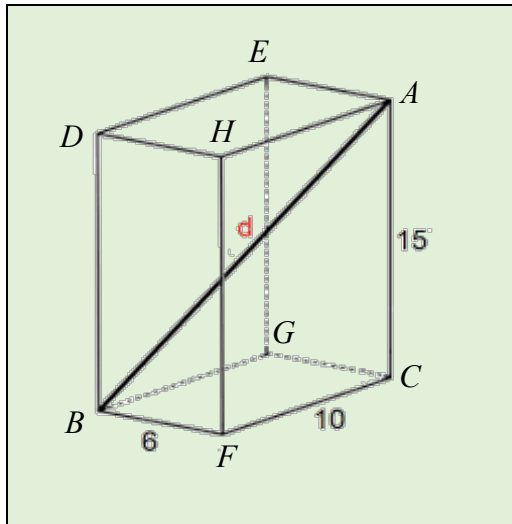

To calculate the diagonal that connects A to B is also the hypotenuse of the right-angled triangle, ABC .

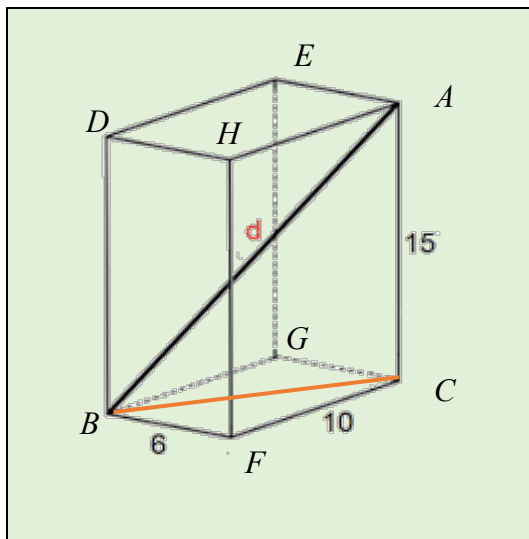

To calculate AB, we must first calculate BC. Since the solid is a cuboid, the base is a rectangle and all its vertices will be right angles. So using Pythagoras' theorem, we have:

$$\begin{aligned} BC^2 &= 6^2 + 10^2 \\ BC^2 &= 36 + 100 = 136 \\ BC &= \sqrt{136} \\ BC &= 11.7 \text{ units} \end{aligned}$$

Applying Pythagoras' theorem to the right-angled triangle, ABC , we have:

$$\begin{aligned} AB^2 &= AC^2 + BC^2 \\ AB^2 &= 225 + 136 \\ AB^2 &= 361 \\ AB &= \sqrt{361} \\ AB &= 19 \end{aligned}$$

Notice that the diagonal AB is the same length as any diagonal from two similar vertices such as DC , EF and GH .

The angle between a line and a plane

To identify an angle between a line and a plane in the above cuboid, we may first consider the vertical line, AC and the plane $BGCF$. The angle between this line and the plane is angle, $ACB = 90^\circ$.

Now consider the internal diagonal, AB and the plane $BGFC$. This makes an angle, α with the plane $BFCG$.

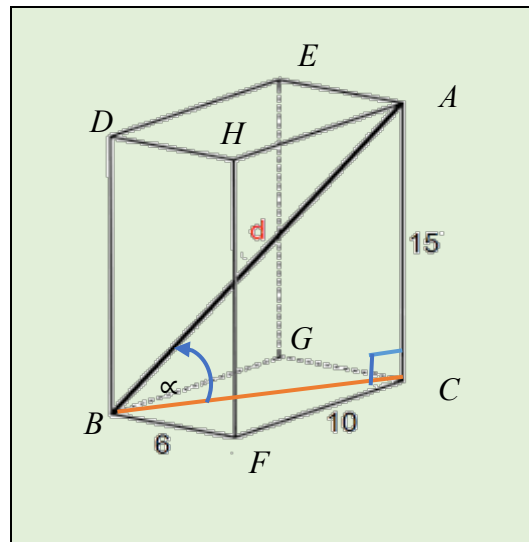

To calculate α , we can use the triangle ABC and any trigonometric ratio. Selecting the sine ratio, we have:

$$\begin{aligned} \sin \alpha &= \frac{AC}{BA} \\ \sin \alpha &= \frac{15}{19} \\ \alpha &= \sin^{-1} \left(\frac{15}{19} \right) \\ \alpha &= 52.1^\circ \end{aligned}$$

Example 9

A vertical flagpole OP stands at the centre of a horizontal field $QRST$. Using the information in the diagram, not drawn to scale, calculate the height of the flagpole.

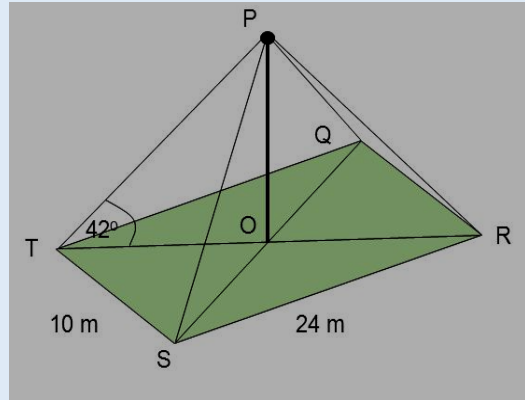

Solution

$$\begin{aligned} TR^2 &= TS^2 + SR^2 \\ TR^2 &= 10^2 + 24^2 \\ TR^2 &= 676 \\ TR &= \sqrt{676} \\ TR &= 26 \\ TO &= 26 \div 2 = 13 \end{aligned}$$

$$\begin{aligned} \tan 42^\circ &= \frac{OP}{TO} \\ \tan 42^\circ &= \frac{OP}{13} \\ OP &= 13 \times \tan 42^\circ \\ OP &= 11.7 \end{aligned}$$

Example 10

The diagram shows a cuboid. A straight adjustable wire connects R to P along the top of the cuboid.

- Calculate the length of RP .
- The connection at P is now adjusted and moved to T . Calculate the length of the wire RT .
- Calculate the angle TRV .

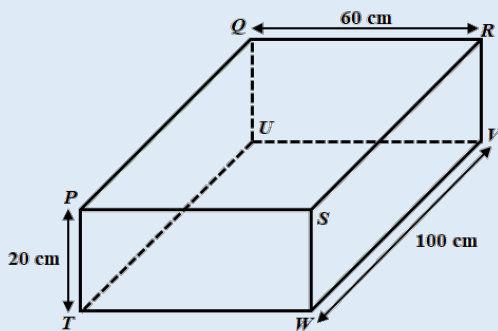

Solution

(i)

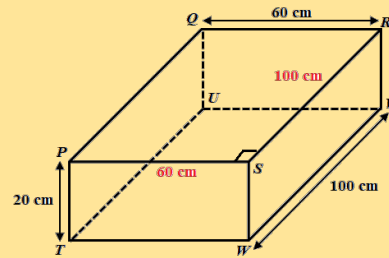

Consider triangle PRS :
 $RP^2 = 60^2 + 100^2$
 $RP^2 = 13\,600$
 $RP = \sqrt{13\,600}$
 $RP = 116.61$
 $RP = 116.6 \text{ cm}$ correct to 1dp

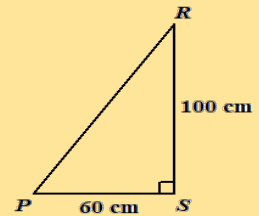

(ii)

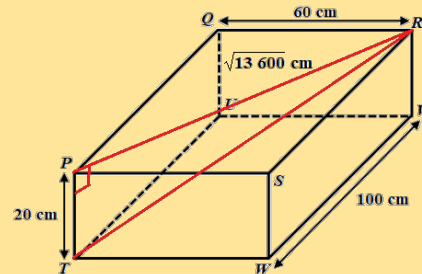

Consider triangle PRT :
 $RT^2 = 20^2 + (\sqrt{13\,600})^2$
 $RT^2 = 400 + 13\,600$
 $RT = \sqrt{14\,000}$
 $RT = 118.3 \text{ cm}$ correct to 1dp

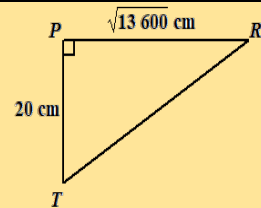

(iii)

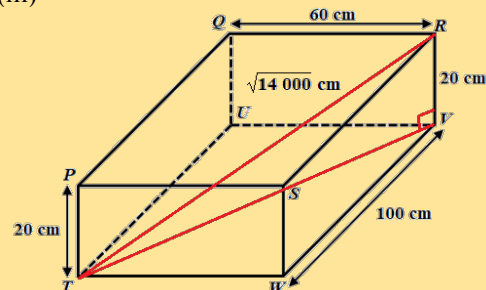

Let $TRV = \alpha^\circ$
 $\cos \alpha = \frac{20}{\sqrt{14\,000}}$
 $\alpha = \cos^{-1}\left(\frac{20}{\sqrt{14\,000}}\right)$
 $\alpha = 80.3^\circ$ to 1dp

